

# E710



EXPANDABLE



QUICK START



40° MIN.  
ROTATION



BARCODE  
ENTERING



## SHAFT ALIGNMENT

Professional measurement and alignment system for rotating machines

**EASY-LASER®**



# A PRECISION CHOICE

*is also a safe choice!*

## LONG EXPERIENCE

Easy-Laser® measurement systems have been developed from more than twenty five years experience of solving measurement problems for the industry. This is long enough to understand problems out in the real world. At the same time, we are young enough to see opportunities and solutions with fresh eyes. Our development department consists of designers who specialise in mechanics, electronics, optics and programming. Taking full control from the initial idea to the finished product and working closely with our users, we are able to create user-friendly measurement systems.

## LONG TERM AND RELIABLE

Our philosophy is that the products we develop must not only have long operating times but also a long lifecycle. We design our products to be robust, with as few small parts as possible. The Easy-Laser® measuring systems can therefore withstand rough handling and work with the greatest precision in the most demanding environments, year after year. Easy-Laser® is a dependable and safe choice from every point of view.

## FAST SERVICE AND SUPPORT

Easy-Laser® measurement systems are available from local dealers in more than 70 countries, but there are users to be found in many more countries. For them, professional tools and the best possible support are of great importance, and the same is no doubt true for you as well. Service and repair centres can be found all over the world for your convenience. You can be assured that we will provide you with the fastest and best possible support. Our service department usually takes care of servicing or calibration within five working days. As an extra service, we provide a 48-hour express service for when accidents occur and time is of the essence. Contact us for further information about terms and conditions.

## LARGE SAVINGS

Easy-Laser® measurement systems are already extremely flexible in their standard form. By using clever accessories, you can adapt the systems for your own needs, now and in the future as your measurement requirements change. It is cost-effective. Your production capacity increases by being

able to measure faster and with greater reliability. Easy-Laser® helps you remedy production errors quickly and easily. This can save you large amounts of money, and your investment can even be repaid within a few months.

## ONE SYSTEM, MANY POSSIBILITIES

Easy-Laser® offers what is probably the most competent and cost-effective measuring system for rotating machines on the market! Using a single instrument, you now have the potential to trouble-shoot and prevent wear and breakdowns in your machines.

Easy-Laser® E710 allows:

- SHAFT ALIGNMENT
- SHEAVE/PULLEY ALIGNMENT
- VIBRATION MEASUREMENT
- TWIST MEASUREMENT OF BASES
- STRAIGHTNESS MEASUREMENT
- BEARING PLAY CHECKS



## OUR BEST ARGUMENTS

- The measurement system for all stages of machine set-up.
- Easy to learn and to use.
- 2 year warranty gives assurance.
- Fast service and support. 48-hours Express service if necessary.
- Ergonomic design.
- Low overall costs during the entire lifecycle of the product, for example servicing, accessories, etc.
- Endurio™ Power management system ensures that you never have to stop in the middle of a measurement because the battery has run out.
- Expandable / Adaptable  
A range of accessories means that you can adapt the measurement system to your needs, now and in the future.

# SIMPLE AND EFFECTIVE

*Easy to use = Fast and efficient!*



## NEW FEATURE! NOW WITH BARCODE READER



The barcode reader is used to enter the machine dimensions with literally one swipe. Then it is just a question of continuing the measurement procedure. It couldn't be quicker and easier!

*Measurement and alignment should be easy! That is the fundamental philosophy behind our measurement systems. When we talk about simplicity we mean several things, for example, simple to place or mount the measurement equipment on the measurement object, easy to perform the measurement and easy to interpret the measurement result. Simple to use = quick and easy!*

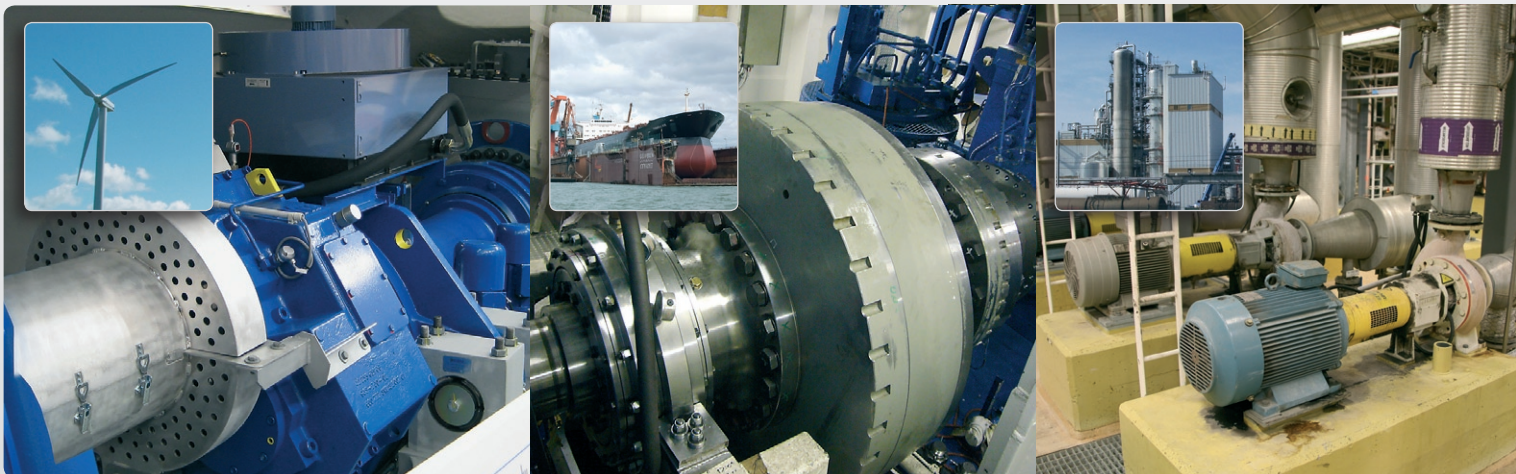

Easy-Laser® is used to align generators and gearboxes in wind turbines of a number of sizes and makes. Special brackets are available (accessories) for alignment with locked rotors, which increases the safety for the operator.

Engines, gearboxes and propeller shafts on ships are aligned using Easy-Laser® system. Thanks to flexible brackets you can install the equipment in the most appropriate place; shaft, coupling or flywheel.

Easy-Laser® is used to align pumps and motors for all types of industries and installations. Correctly set-up and aligned machines are a requirement for achieving optimum service life and minimal energy consumption.

# SHAFT ALIGNMENT

## HORIZONTAL MACHINES



Horizontally coupled machines often consist of a pump and motor, but there can also be other types of machine such as gearboxes and compressors. Regardless of what the machine is it is easy to measure and align with Easy-Laser®. The measuring units (M and S) are mounted on each side of the coupling with cable or wireless communication to the display unit. Then follow the step-by-step instructions on screen (see below).

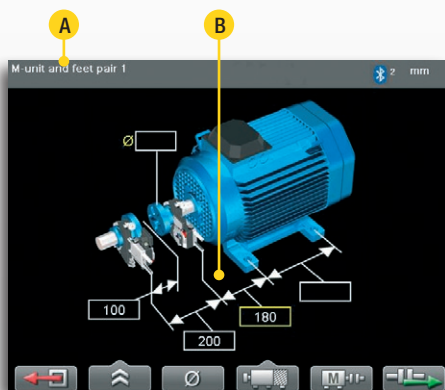

1. Enter the distances between measuring units and the machine feet. If you enter the coupling diameter you can also get the result as gap/sag.

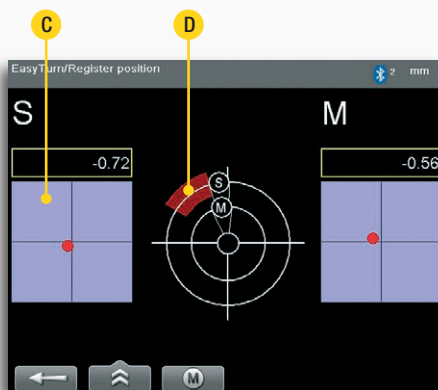

2. Take the measurement values in three positions with as little as 20° between. It is clearly visible on the display when the laser beam hits the detector.

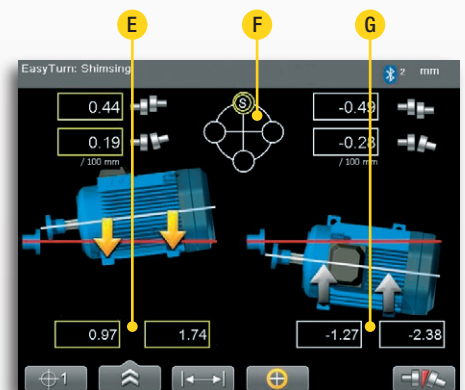

3. The live values are used to adjust the machine. For clarity the adjustment is displayed both graphically and numerically. Horizontal and Vertical directions are shown at the same time.

**A.** Information field. States what you must do at each stage of the measurement. Also displays Bluetooth® connection, warning symbols etc.

**B.** You can start from a previous measurement and so avoid re-entering the dimensions, the barcode reader is the fastest method.

**C.** The detector surface is shown on the screen and functions as an electronic target for the laser beams.

**D.** 20° marking. The S unit position on the shaft is shown. You can also choose to show the M unit when you align uncoupled machines.

**E.** Shims values for front and rear pairs of feet. Colour coded in order to determine the result more quickly: red=outside tolerance, green=inside tolerance.

**F.** The measuring unit position on the shaft.

**G.** Horizontal adjustment values. Colour coded.

## SOFT FOOT CHECK



Start the alignment work by performing a soft foot check to ensure the machine is resting evenly on all its feet. This is necessary for a reliable alignment. The program shows which foot (feet) should be corrected. After the soft foot check you can go directly to the alignment program with all of the machine's distances saved.

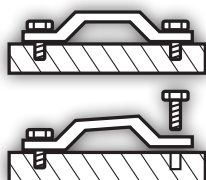

## EASYTURN™ FUNCTION



With the EasyTurn™ function you can start measurement anywhere on the turn. Turn the shafts with the measuring units to three positions in any direction with as little as 20° between to register the measurement value. Measurement is complete!

*Start measurement at any position!*

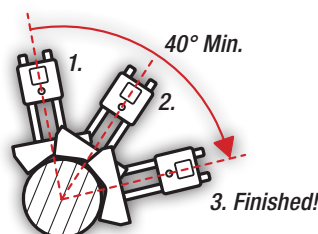

## THERMAL GROWTH COMPENSATION



In many cases, the machines (for example a pump and motor) expand considerably from a cold to a hot state (operating temperature). The Thermal Growth Compensation function allows the measurement system to calculate the correct shims and adjustment values even in such cases. The compensation values for the machines are normally supplied by the manufacturers.

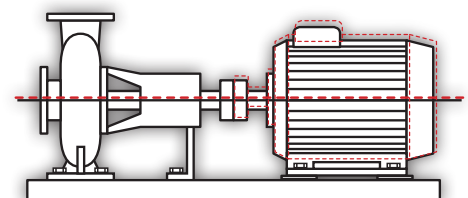

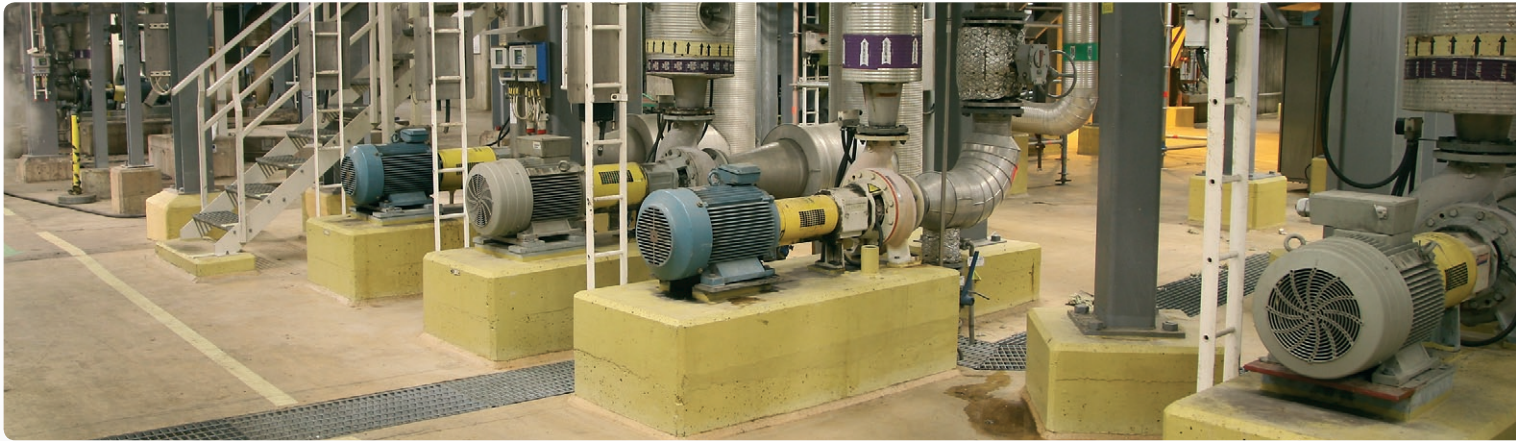

### VERTICAL/FLANGE-MOUNTED MACHINES



Alignment of vertical and flange-mounted machines. Shows centre offset, angular error and shim value at each bolt.

### CARDAN/OFFSET-MOUNTED MACHINES



Alignment of cardan/offset mounted machines. (Accessory Cardan fixture, Part No. 12-0615 is required.)

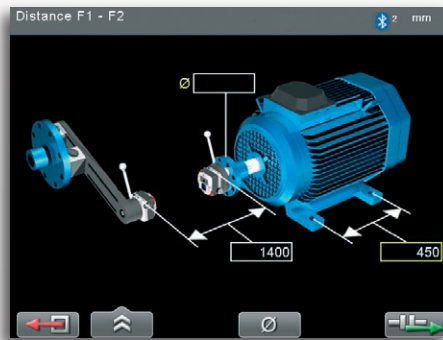
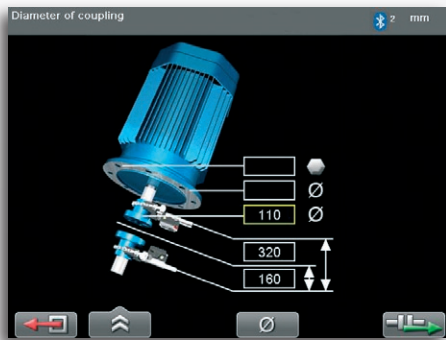

### TOLERANCE CHECK



Measurement results can be checked against pre-defined tolerance tables or values you determine yourself. In this way, you can see immediately whether the alignment is within the approved tolerances. This means the times for alignment are shortened considerably.

### REFERENCE FOOT LOCKING



This function allows you to lock any pair of feet on the machine. This gives great freedom when aligning base-bound or bolt-bound machines.

### MEASUREMENT VALUE FILTER



Advanced electronic filter function that can be used for a reliable measurement result even in a very poor measurement environment, for example where there is air turbulence from open entrances or vibrations from adjacent machines.

### LIVE-ANY-ANGLE 360°



This function allows adjustment of the machines live with the measuring units positioned anywhere around the shaft. Good for when machine parts prevent normal adjuster positioning.

### THREE PAIRS OF FEET / PAIR OF FEET IN FRONT



The software can handle machine design of all types: two pairs of feet, three pairs of feet, pair of feet before the coupling etc.

# MANY OPTIONS

## SHEAVE/PULLEY ALIGNMENT



Using the system you can align sheaves and pulleys with digital precision. Adjustment of the machines is displayed in real time on the screen, with readings for angle and axial displacement in both the vertical and horizontal axes, as well as an adjustment value for the front or rear foot pair. The result can be documented as normal. (Requires the BTA Digital accessory.)

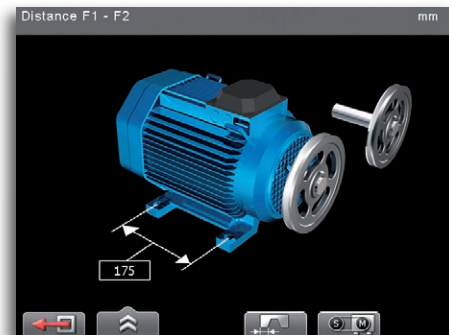

## VIBRATION MEASUREMENT AND BEARING CONDITION



You can measure vibration levels (mm/s, inch/s) and bearing condition (g-value). The result can be documented as normal. (Requires the Vibrometerprobe accessory.)



## CHECKING BEARING PLAY

V 0.00  
H 0.00

All our measurement systems come with the extremely useful Values program. The program can be used e.g. when one wants to measure as with dial gauges and to check bearing play. With the standard equipment and completely normal set up on the machine!

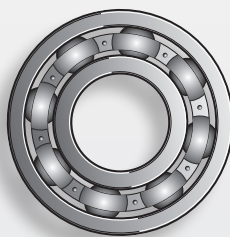

## FLATNESS MEASUREMENT OF BASES



With the value program you can, in principle, measure any type of geometry, for example flatness and twist of the base. If you add a separate laser transmitter such as Easy-Laser® D22 you extend the area of application even more. Many Easy-Laser® users therefore end up using the measurement system in more places in their operation than they first intended!

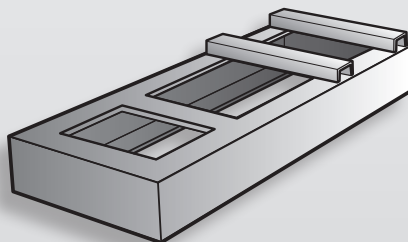

## A MEASURING SYSTEM FOR ALL STAGES OF MACHINE SET-UP

With Easy-Laser® the same system is used to reassure yourself that the machines have optimal conditions for problem-free operation, without risk of unplanned downtime etc. Carry out the following:

- Check the base
- Check vibration level
- Check bearing play
- Check soft foot
- Measure the machine
- Align the machine
- Document the results

# DOCUMENTATION

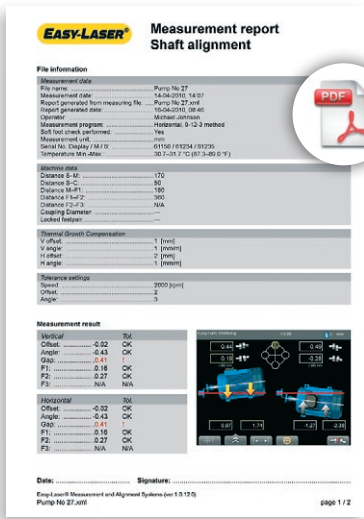

## CREATE A PDF REPORT DIRECTLY

When measurement is complete it is possible to generate a PDF report containing graphs and measurement data directly in the measurement system's display unit. All the information about the measurement object is documented, and you can add your company's logo and address details if you so wish.

## SAVING IN THE BUILT-IN MEMORY

You can, of course, save all measurements in the display unit's internal memory.

## SAVE TO USB MEMORY

You can easily save desired measurements on your USB memory. This enables you to take it to your computer to print reports whilst leaving the measurement system in place.



## CONNECT TO YOUR COMPUTER

The display unit is connected to the computer via the USB port. It then appears on the desktop as a USB Mass Storage Device which you can easily transfer files to and from.

## BARCODE READER

The barcode reader is used to enter the machine data before measurement. At the first measurement of the machine apply the adhesive bar code label. Next time the machine is checked the dimensions are read in directly. Also any compensation values. This makes it easier for new operators who don't need to search through long lists of machine templates with descriptions that are difficult to understand. Quite simply, easier to do correctly!

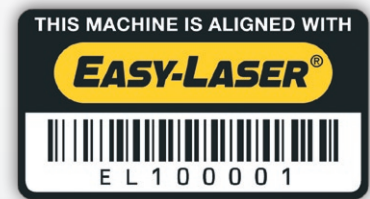

## MAJOR BENEFITS OF ALIGNMENT

You have much to gain in both time and money through having your machines aligned to the correct tolerances. An investment in a laser based alignment system such as Easy-Laser® rapidly pays for itself through lower costs for replacement parts, less downtime and smaller electricity bills. Correctly aligned machines reduce the risk of expensive breakdowns and downtime. The benefits of alignment are many:

- Increased availability and productivity of the machine = *assured production*
- Increased life of bearings and seals = *less use of replacement parts*
- Complete seals = *less leakage and better working environment*
- Optimally utilised lubricant = *less risk of overheating and secondary damage*
- Less lubricant leakage = *less lubricant consumption*
- Reduced friction = *lower energy consumption*
- Less vibration = *reduced noise level*
- Less risk of serious breakdowns = *safer working environment*

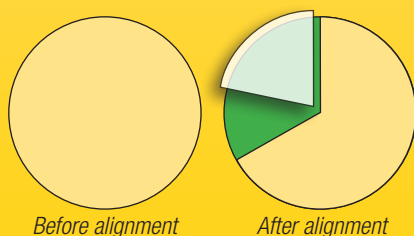

- Maintenance costs and operation per annum
- Saving after alignment per annum\*
- Cost of investing in Easy-Laser®

## ADVANTAGES OF LASERS

There are many advantages to aligning using lasers compared to more traditional methods such as using dial gauges:

- Easy to learn and to use
- Stable brackets without play and slack
- Much faster to mount
- Automatically calculated shims/adjustment values
- Simple tolerance check
- Simple compensation for thermal expansion
- No risk of read off errors
- Possible to document the result

Other old methods such as rulers and feeler gauges are not sufficiently accurate for today's modern machines. With a laser based alignment system checks are easy and fast to carry out. If you choose Easy-Laser® you also have a measurement system that has many more uses in the workplace than merely aligning shafts.

\*The diagram is an estimate of the savings/costs relationship and is naturally dependent on the industry.

# SYSTEM PARTS

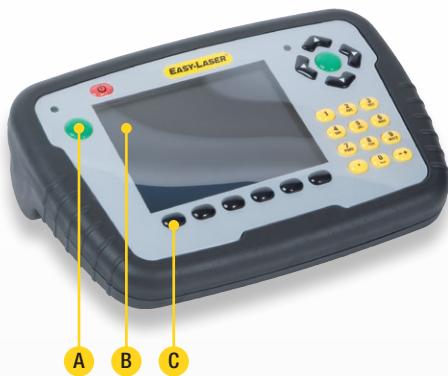

- A. Two Enter buttons, for left and right-handed users
- B. Large, easy to read 5.7" colour display
- C. Proper buttons for clear feedback



- D. Thin profile gives a perfect grip for your hands
- E. The integrated battery compartment design gives the correct angle on the display screen
- F. Battery compartment
- G. Mounting for shoulder strap

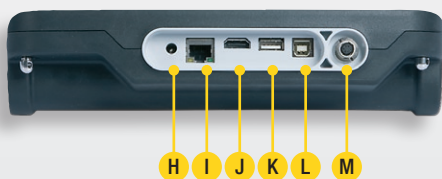

- H. Connection for charger
- I. Network connection
- J. Expansion port
- K. USB A
- L. USB B
- M. Easy-Laser® measurement equipment



- N. Dust and splash guards for sockets that are not used when measuring
- O. Robust, rubber coated design

## DISPLAY UNIT

The new display unit for the E-series enables you to work more efficiently and for longer than ever before thanks to several innovative solutions. It is also ergonomically designed with easy-to-grip rubber cladding and robust construction.

### NEVER LOSE POWER!

Easy-Laser® E710 is equipped with our Endurio™ Power management system. This ensures that you never have to stop in the middle of a measurement because the battery has run out. If the internal battery's charge level starts to drop, simply insert the batteries into the integrated battery compartment and continue measuring. This eliminates the need to look for a wall socket, and means you do not have to wait a few hours for the unit to charge before starting work again. Shouldn't it always have been this way? The unique Endurio™ system also checks all the electronics so that the unit consumes as little power as possible in each position.



### ERGONOMIC DESIGN

The display unit has a thin, easy-to-grip and rubber coated profile that ensures a secure grip. It has large well-spaced buttons that give clear feedback when pushed. In addition, the two Enter buttons make the system suitable for both right and left-handed users. The display screen has clear graphics that guide you through the measurement process.



Calculator

### CALCULATOR

We have integrated a calculator and conversion tool for length units in the display unit.

### PERSONAL SETTINGS

You can create a user profile where you can save your personal settings. You can also have different settings for different types of measurements. It makes work faster!

### LANGUAGE SELECTION

You can choose the language that you want to appear on screen. Initially English, German, French, Spanish, Portuguese, Swedish and Chinese are available. More languages to follow.

### UPGRADING

If you wish to expand functionality in the future, the software in the display unit can be upgraded via the internet or by connecting a USB memory containing the new software. In this way you will also have access to the measurement programmes that we develop for new purposes in the future.



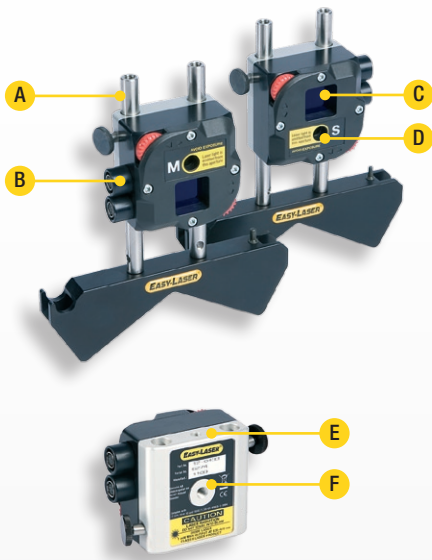

- A. The rods have a height of 120–180 mm. If necessary they can be extended "infinitely" with accessory rods. Made of stainless steel.
- B. Well protected connectors
- C. PSD (2 axis)
- D. Laser aperture
- E. Stable aluminium design
- F. Threaded holes for multiple mounting options

## MEASURING UNITS

The measuring units have large 20 mm [0.78" sq] detector surfaces (PSD for the greatest accuracy) which allows the possibility of measuring at a distance of up to 20 metres [66 feet]. The substantial and rigid design of aluminium and stainless steel guarantees stable measurement values and reliable alignment with the greatest precision in even the toughest of environments. The measuring units are also water and dust proof to classes IP66 and IP67. Connect to the display unit via cable or wirelessly. Both cable and wireless units are connected quickly using Push/Pull connections, no screwing required.

## INCLINOMETERS IN BOTH UNITS

With electronic inclinometers in both measuring units the system knows exactly how they are positioned. This also makes it very easy to align uncoupled shafts.

## ELECTRONIC TARGETS

Thanks to the two axis detectors you have access to electronic targets, that is you can see on the screen where the laser beams hit.

## FLEXIBLE MOUNTING OPTIONS

The thinking behind the rigid and compact design, is that it will simplify positioning and provide varying installation methods. You can measure all types of rotating machine, large and small, equally well, regardless of shaft diameter. The units also have two extra screw holes for additional mounting options.

## TWO LASERS, TWO PSD

The so called reversed measurement method with two laser beams and two PSD makes it possible to also measure very incorrectly set machines. This is particularly good for new installations, where the machines are not yet in the correct position.



## WIRELESS COMMUNICATION

The unit for wireless communication is easily inserted into one of the connectors on the measuring unit. Wireless connection to the display unit enables you to work more freely. Dust and water proof to IP66 and IP67.



## STANDARD BRACKETS INCLUDED IN THE SYSTEM

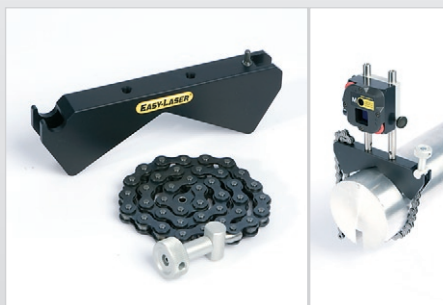

### SHAFT BRACKET WITH CHAIN

For attachment around shaft or coupling. Suitable for diameters of 20–450 mm [0.8"–17.7"] with standard chains.

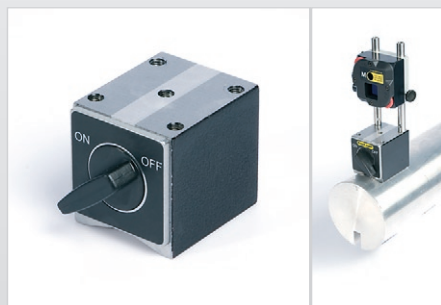

### MAGNET BASE

For direct attachment to shaft or coupling. Very strong and stable. Three magnetic sides give flexible positioning possibilities.

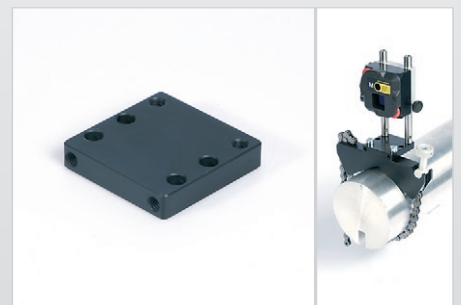

### OFFSET BRACKET

Allow axial displacement between measuring units in order to be able to rotate past projecting machine parts and connectors.

# ACCESSORIES AND EXPANDABILITY

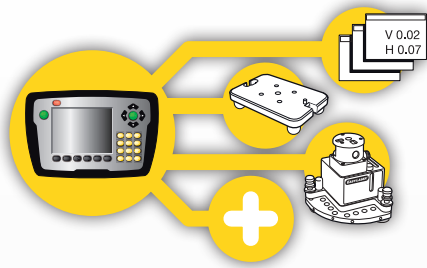

## A FUTURE PROOF CHOICE

Easy-Laser® measurement systems are already extremely flexible in their standard form. By using clever accessories, you can adapt the systems for your own needs, now and in the future as your measurement requirements change. It is cost-effective. We have standardised measurements between the mounting holes in the different parts, and often there are mounting holes

on several sides to facilitate mounting on the machine. Experience tells us that this is very much appreciated. A further advantage is that you can use one of the measuring units separately as a detector with, for example, our geometric laser D22. This expands the areas of application of the measurement system. Easy-Laser® is a system that is complete in its full meaning!

## MAGNETIC BRACKET

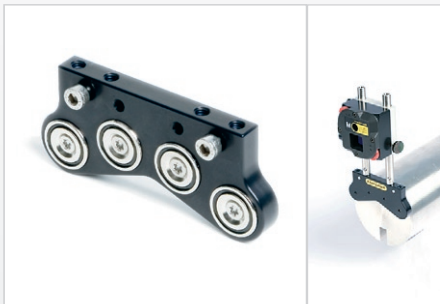

Bracket for axial mounting on flange or shaft end. With four super magnets.  
Part No. 12-0413

## THIN SHAFT BRACKET

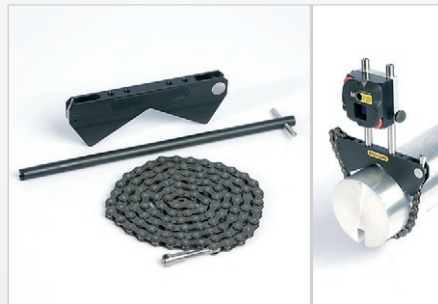

This is used, for example, when there is limited space between the coupling and machine. Thin chain and lock tools included. Width: 12 mm [0.47"]. Part No. 12-0412

## SLIDING BRACKET

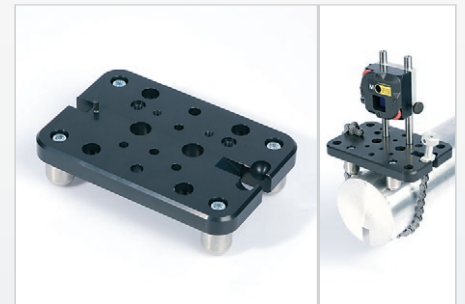

Used when the shafts cannot be rotated. The spherical feet give a stable position against the shaft. Mounted with standard chains.  
Part No. 12-0039

## CARDAN BRACKET



For alignment of Cardan/offset mounted machines. Part No. 12-0615

## EXTENSION RODS



Screwed together. Extendable theoretically "unlimited".  
Length 60 mm [2.36"], (4 x) Part No. 12-0059  
Length 120 mm [4.72"], (8 x) Part No. 12-0324  
Length 240 mm [9.44"], (4 x) Part No. 12-0060

## EXTENSION CHAINS

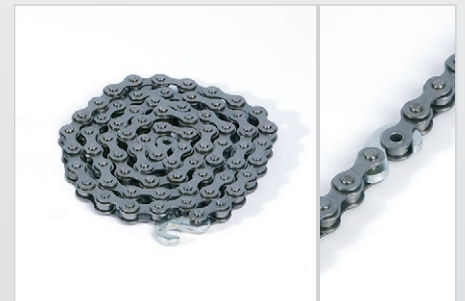

Makes it possible to align very large shafts.  
Length: 900 mm [35.4"], (2 x) Part No. 12-0128



#### ADDITIONAL POWER SUPPLY



Chargeable battery pack which gives extra operating time.  
Part No. 12-0617

#### CHARGER 12–36 V



To charge the display unit via 12–36 V socket, for example in a car. Part No. 12-0585

#### EXTENSION CABLES



Length 5 m [16.4'],  
Part No. 12-0108  
Length 10 m [32.8'],  
Part No. 12-0180

#### PROTECTIVE COVER



Protective case for display unit. With shoulder strap.  
Part No. 01-1379

#### BARCODE READER



Barcode reader for registration of machine data. Connected in the USB port. Part No. 12-0619

#### VGA KIT



Makes it possible to show display unit screen image with a projector, for example in a training context. Must be factory installed on order. Part No. 12-0573

#### TARGET



Simplifies the rough alignment at very long distance and large alignment fault.  
Part No. 12-0588

#### SUN PROTECTION FOR PSD



To screen against extremely strong ambient light.  
Part No. 12-0587

#### LASER TRANSMITTER WITH SWEEP FUNCTION AND ANGULAR PRISM

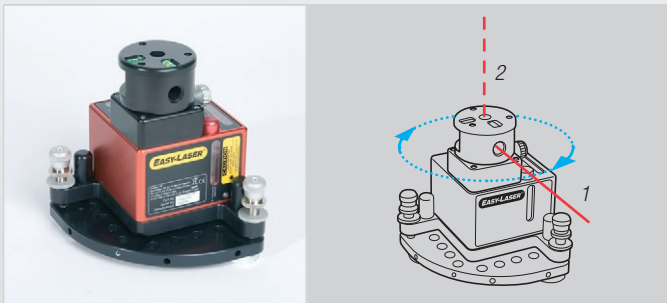

Laser transmitter D22 can be used to measure flatness, straightness, squareness and parallelism. The laser beam can sweep 360° (1) with a measurement distance of up to 40 metres [130'] in radius. The laser beam can be angled 90° to the sweep (2), within 0.01mm/m [0.5 mils/thou]. Part No. 12-0022.

# TECHNICAL DATA

## System

Relative humidity	10–95%
Weight (complete system)	10 kg [22 lbs]
Carrying case	WxHxD: 500x400x200 mm [19.7"x15.7"x7.9"]
	Drop tested (3 m/10 feet). Dust and water proof.

## Measuring units M / S

Type of detector	2-axis PSD 20x20 mm [0.78" sq]
Resolution	0.001 mm [0.05 mils]
Measuring errors	±1% +1 digit
Measurement range	Up to 20 m [66 feet]
Type of laser	Diode laser
Laser wavelength	635–670 nm
Laser class	Safety class II
Laser output	<1 mW
Electronic inclinometer	0,1° resolution
Thermal sensors	± 1° C accuracy
Environmental protection	IP class 66 and 67
Temperature range	-10–50 °C
Internal battery	Li Po
Housing material	Anodized aluminium
Dimensions	WxHxD: 60x60x42 mm [2.36"x2.36"x1.65"]
Weight	202 g [7.1 oz]

## Display unit

Type of display/size	VGA 5.7" colour screen, backlit LED
Displayed resolution	0.001 mm / 0.05 thou
Power management	Endurio™ system for unbroken power supply
Internal battery (fixed)	Heavy duty Li Ion chargeable
Battery compartment	For 4 x R14 (C)
Operating time	Approx. 30 hours (at typical user cycle)
Temperature range	-10–50 °C
Connections	USB A, USB B, External, Easy-Laser® units, Network
Wireless communication	Class I Bluetooth® wireless technology
Internal memory	>100 000 measurements can be saved
Help functions	Calculator, Unit converter
Environmental protection	IP class 65
Housing material	ABS / PC / TPE
Dimensions	WxHxD: 250x175x63 mm [9.8"x6.9"x2.5"]
Weight (without batteries)	1080 g [2.4 lbs]

## Bluetooth® wireless units

Wireless communication	Class I Bluetooth® wireless technology
Temperature range	-10–50 °C
Environmental protection	IP class 66 and 67
Housing material	ABS
Dimensions	53x32x24 mm [2.1"x1.2"x0.9"]
Weight	25 g [0.9 oz]

## Cables

System cables	Length 2 m [78.7"], with Push/pull connectors.
USB cable	Length 1.8 m [70.8"]

## Brackets etc.

Shaft brackets	Type: V-fixture for chain, width 18 mm [0.7"]. Shaft diameters: 20–450 mm [0.8"–17.7"] Material: anodised aluminium
Magnet bases	Holding strength: 800 N
Offset brackets	Displacement: 32 or 16 mm [1.2" or 0.6"]
Rods	Length: 120 mm, 60 mm [4.72", 2.36"] (extendable) Material: Stainless steel

## A complete system contains

1	Measuring unit M
1	Measuring unit S
1	Display unit
2	Bluetooth® units
2	Cables 2 m
2	Shaft brackets with chains
2	Extension chains
2	Magnet bases
2	Offset brackets
4	Rods 120 mm
4	Rods 60 mm
1	Manual
1	Quick reference manual
1	Measuring tape 3 m
1	USB memory
1	USB cable
1	Charger (100–240 V AC)
1	Tool box
1	Shoulder strap for display unit
1	Optical cleaning cloth
1	CD with documentation
1	Carrying case

System Easy-Laser® E710 Shaft, Part No. 12-0440



Easy-Laser® is manufactured by Damalini AB, Åbäcksgatan 6B, SE-431 67 Mölndal, Sweden  
 Tel +46 (0)31 708 63 00, Fax +46 (0)31 708 63 50  
 e-mail: info@damalini.se, www.damalini.com  
 © 2010 Damalini AB. We reserve the right to make changes without prior notification.  
 Easy-Laser® is a registered trademark of Damalini AB.  
 Other trademarks belong to the relevant copyright holder.  
 This product complies with: SS-EN60825-1-1994, 21 CFR 1040.10 and 1040.11



ISO9001  
CERTIFIED

05-0476 Rev1